

[0.18in]
Ø 4.60mm

SECTION A-A

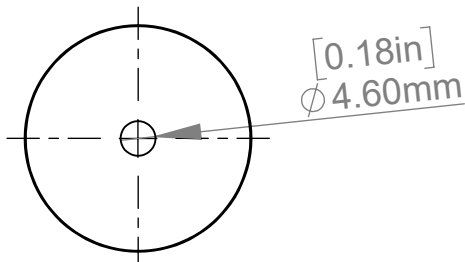

Maximum Thickness

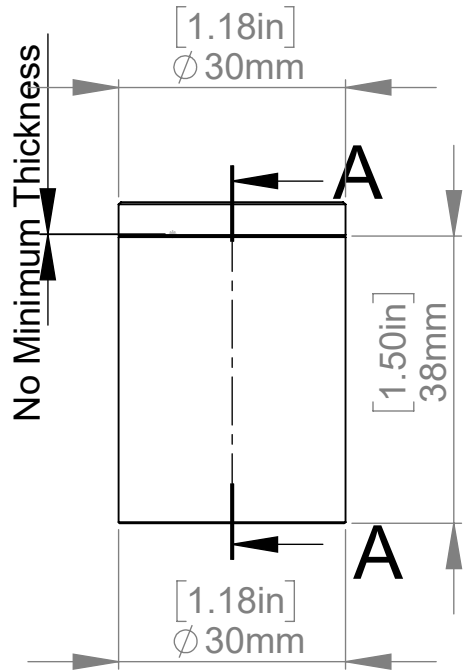
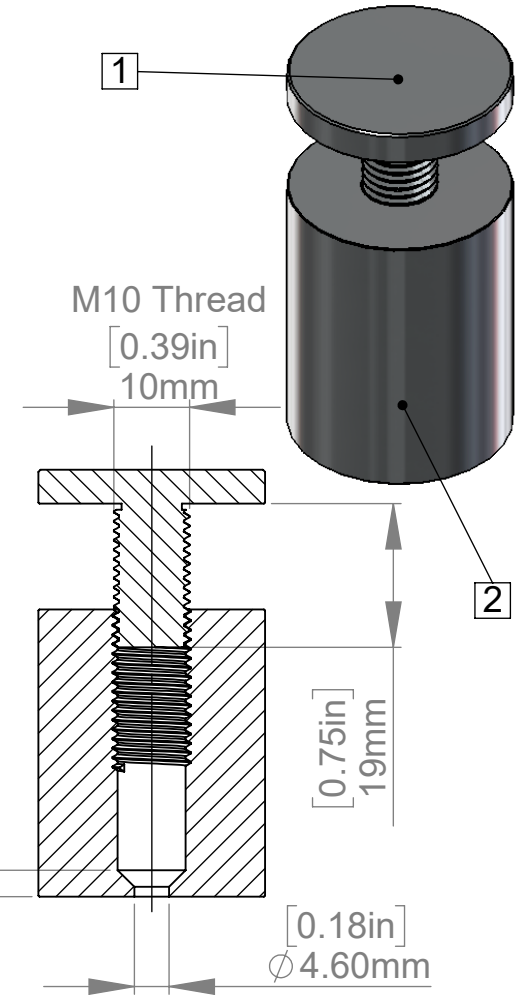
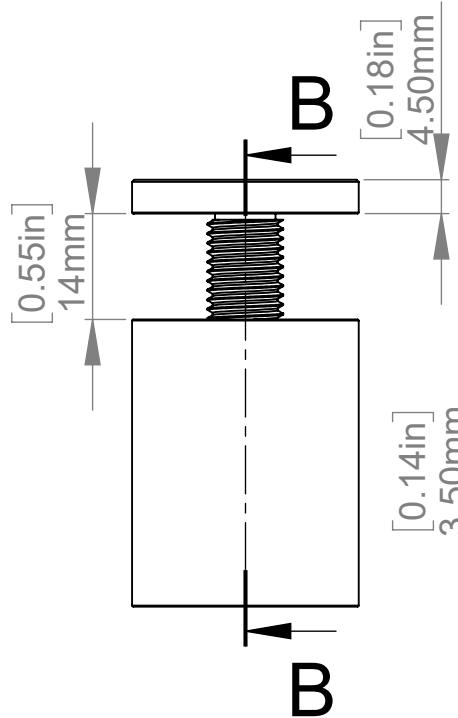

SECTION B-B

ITEM NO.	PART NUMBER	DESCRIPTION	QTY.
1	AS30-38-A		1
2	AS30-38-B		1

Title : AS30-38			Scale : 1:1	
			Sizes : Letter Landscape	
Material:		Finish		Customer:
N°programme laser		N°prog. Mécanum.		Qty : Rep :
		N° Plan : AS30-38		