

[0.18in]
Ø 4.60mm

SECTION A-A

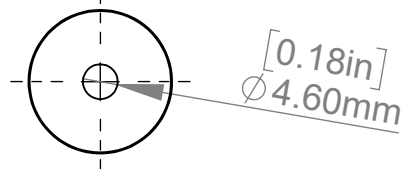

Maximum Thickness

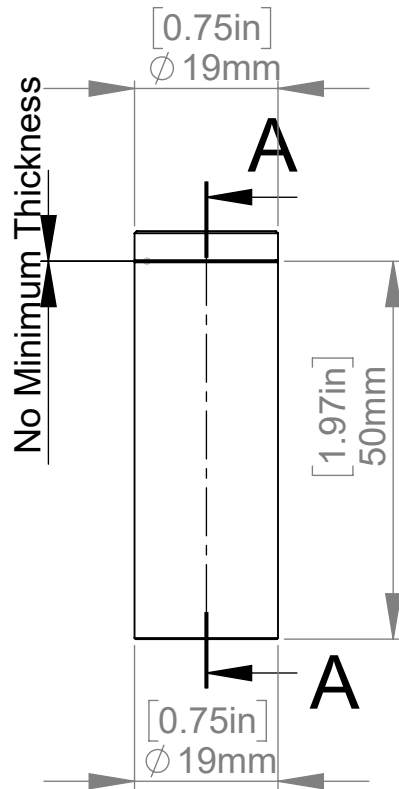
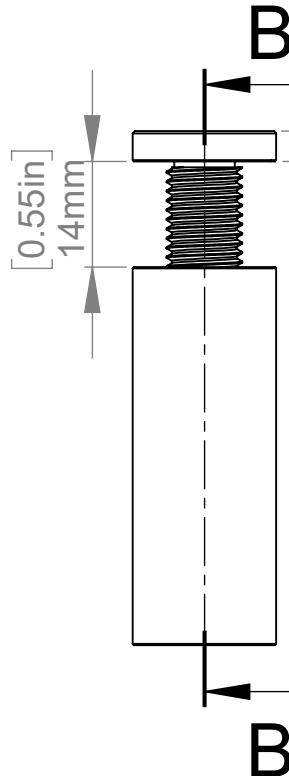

B

[0.14in]
3.50mm

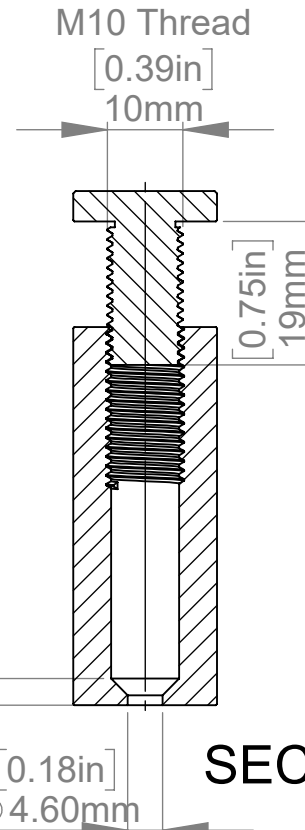

SECTION B-B

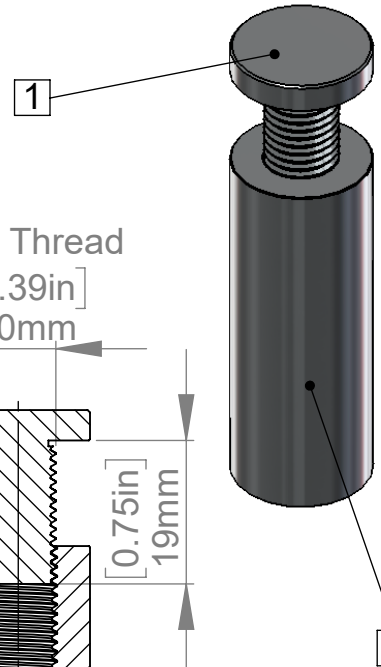

ITEM NO.	PART NUMBER	DESCRIPTION	QTY.
1	AS19-50-A		1
2	AS19-50-B		1

Title : AS19-50		Scale : 1:1	
		Customer:	
Material:		Finish	
N°programme laser		N°prog. Mécanum.	
		Qty :	Rep :
N° Plan : AS19-50			