

Maximum Gap

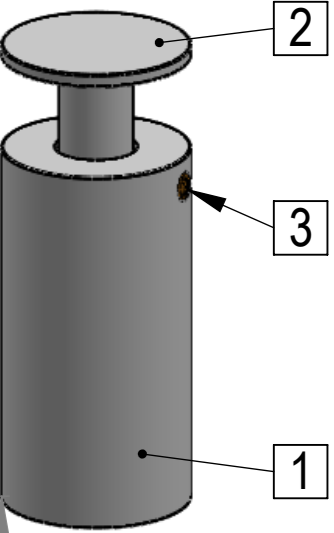

Bit to mark material

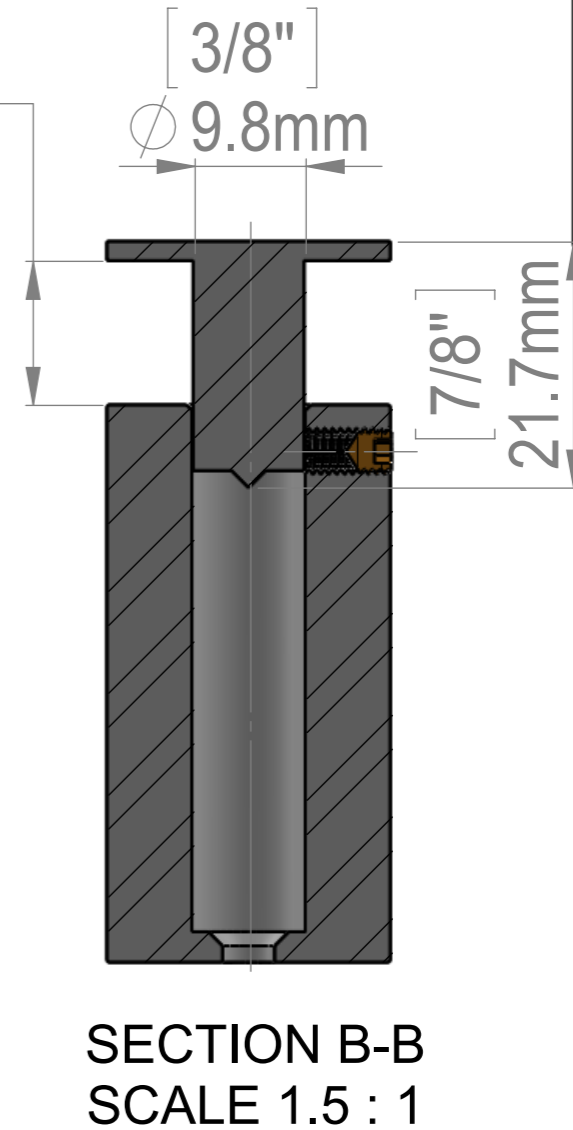
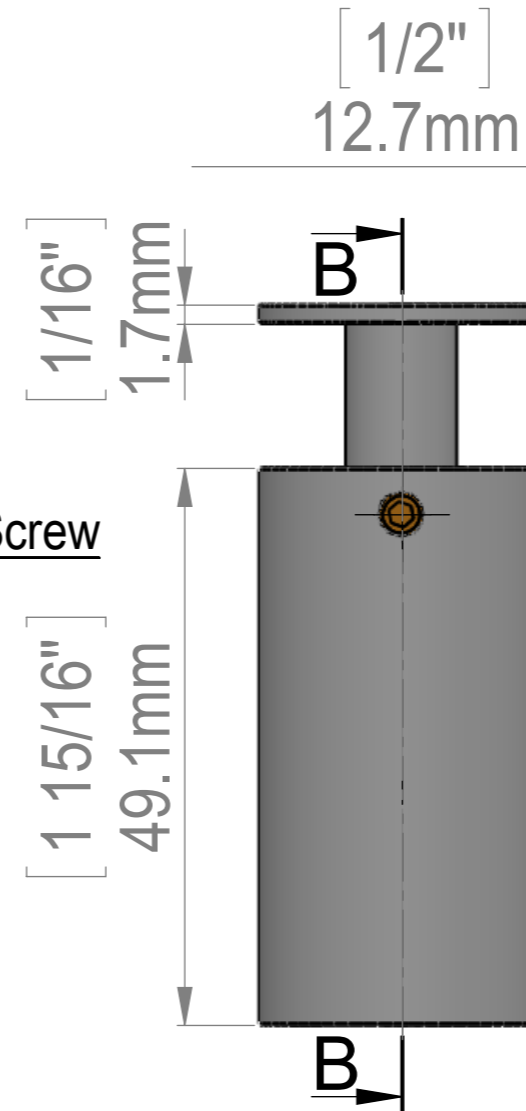
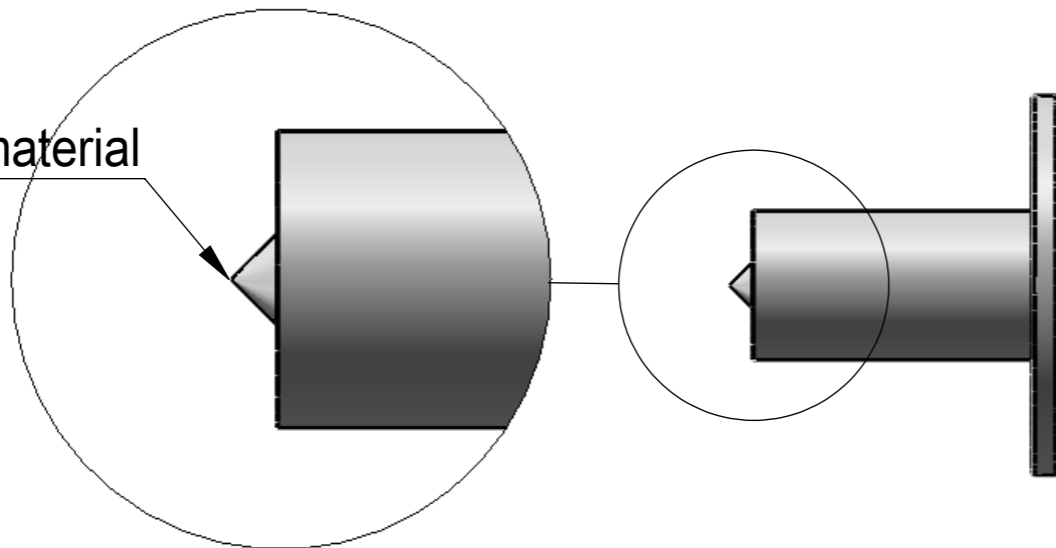

ITEM NO.	PART NUMBER	DESCRIPTION	QTY.
1	GS100-200_Body-25x50		1
2	GS100-100_Head		1
3	Set_Screw_M4xL4mm		1

Title : GS100-200		Scale : 1:1	Customer:	
		Sizes : Letter Landscape	Qty :	Rep :
Material:		Finish		
N°programme laser		N°prog. Mécanum.	N° Plan : GS100-200	