

Attention
Reverse Threaded
For Tamper Proof Purposes

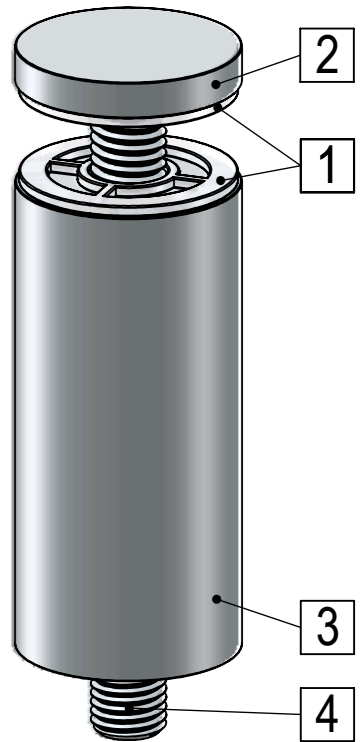
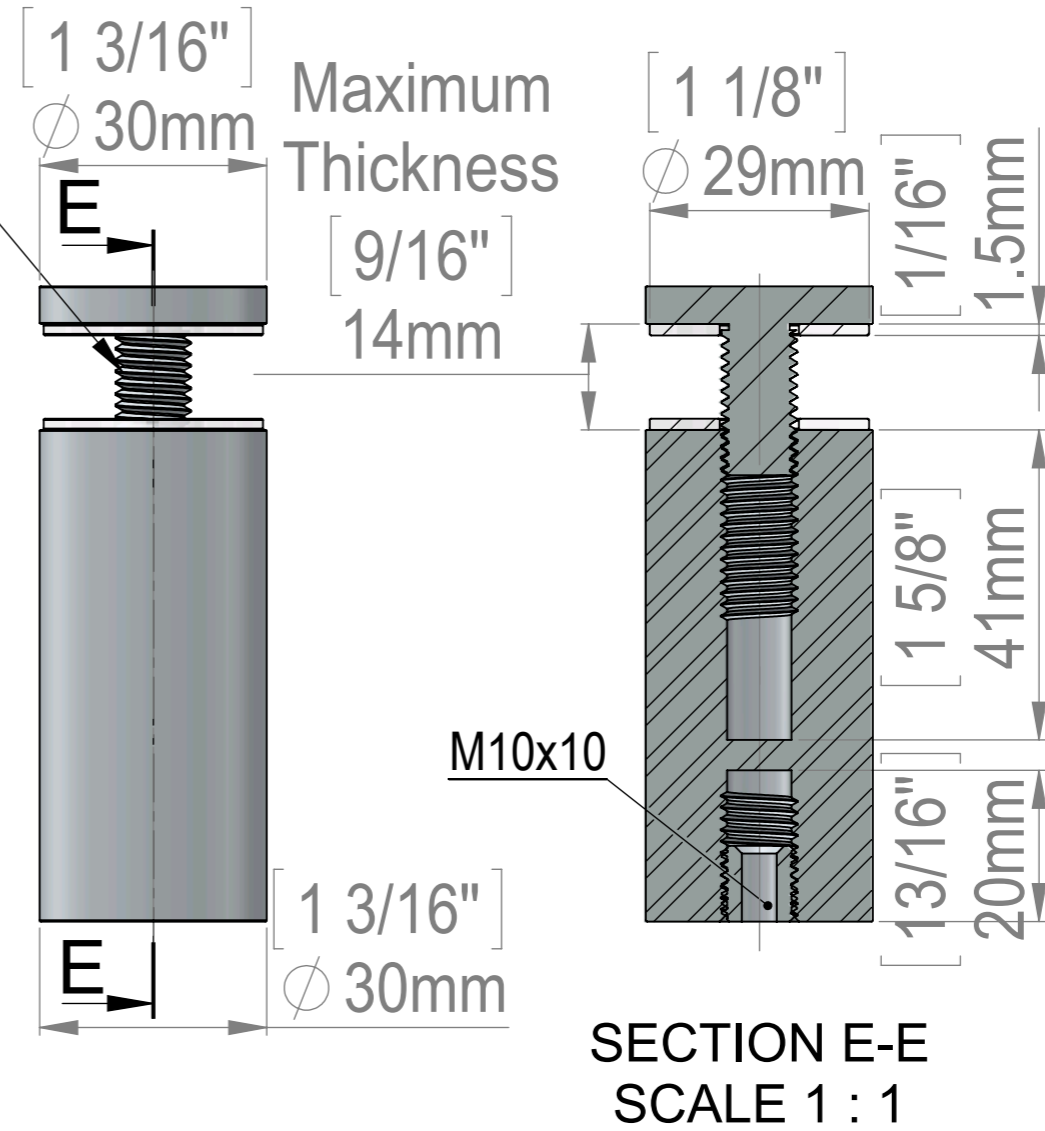
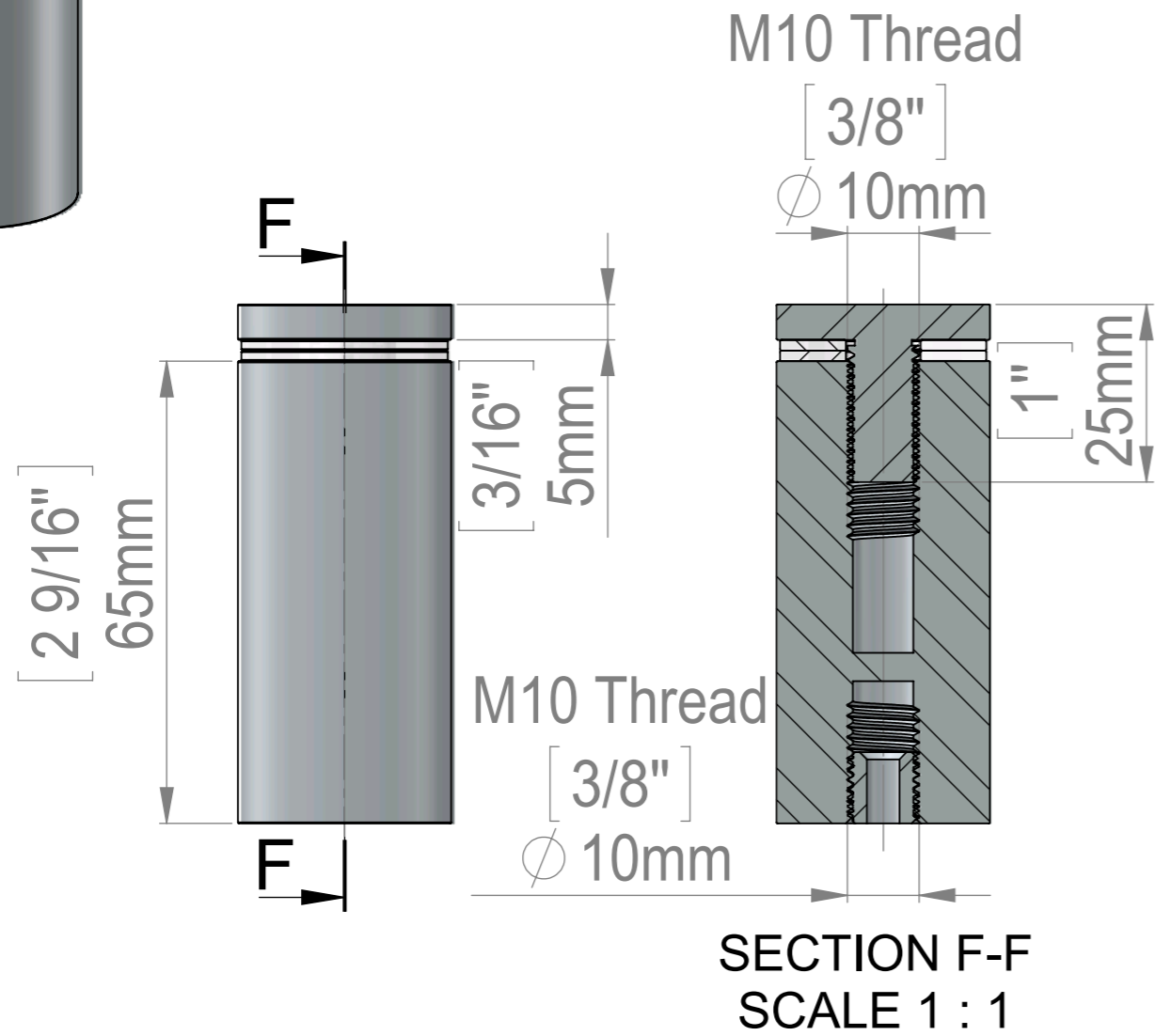

ITEM NO.	PART NUMBER	DESCRIPTION	QTY.
1	FAH30_Washer		2
2	HM1127A(FHA30-25)-Reverse_Thread		1
3	FAH30-70_Body-30x65-Reverse_Thread		1
4	M10x10mm-Screw		1

Title : FAH30-70		Scale : 1:1	
		Customer:	
Material:		Finish	
N°programme laser		N°prog. Mécanum.	
		Qty :	Rep :
N° Plan : FAH30-70			