

Attention
Reverse Threaded
For Tamper Proof Purposes

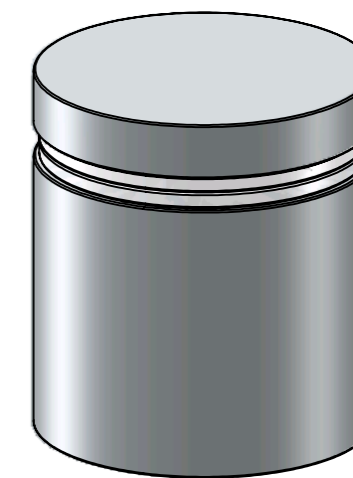
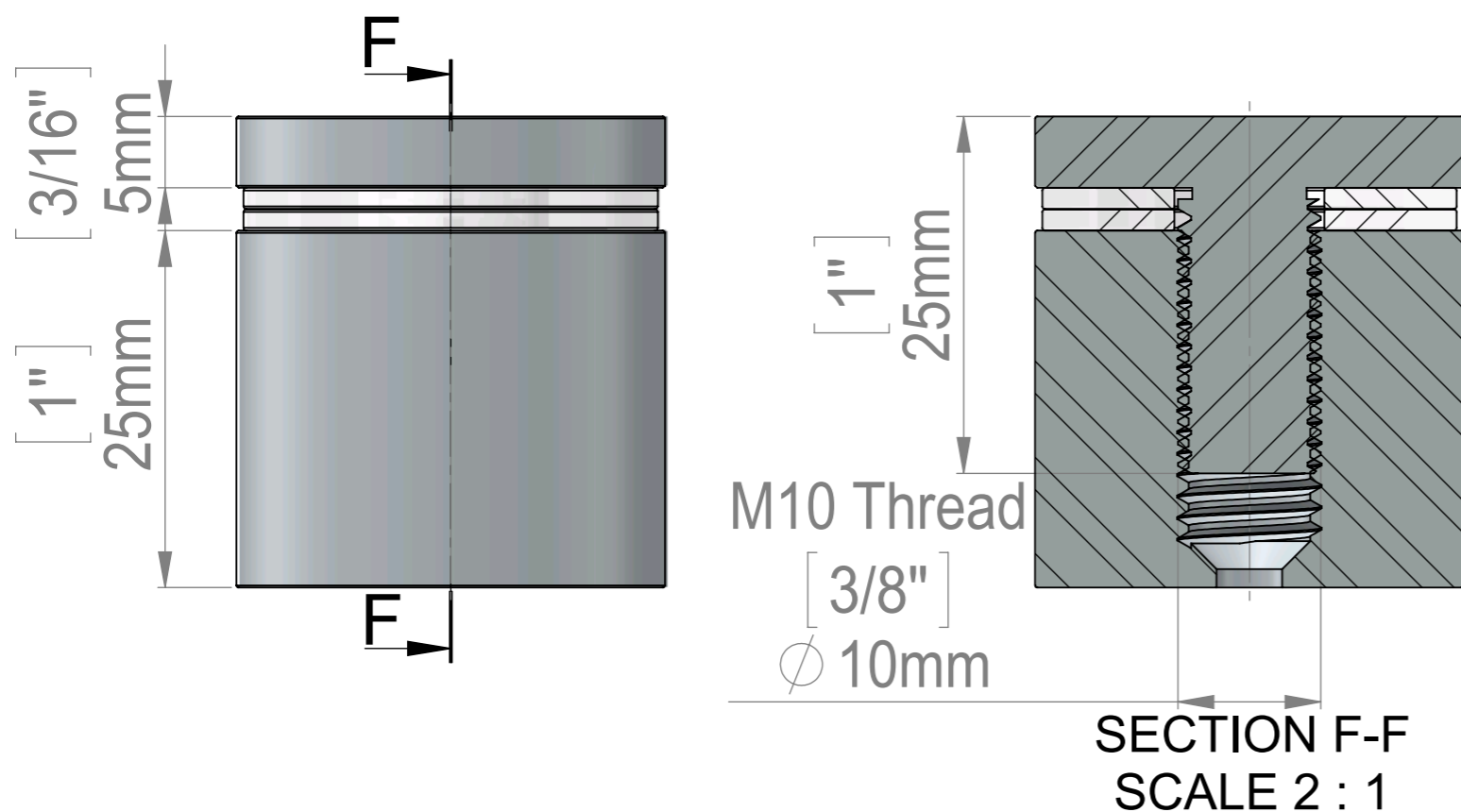
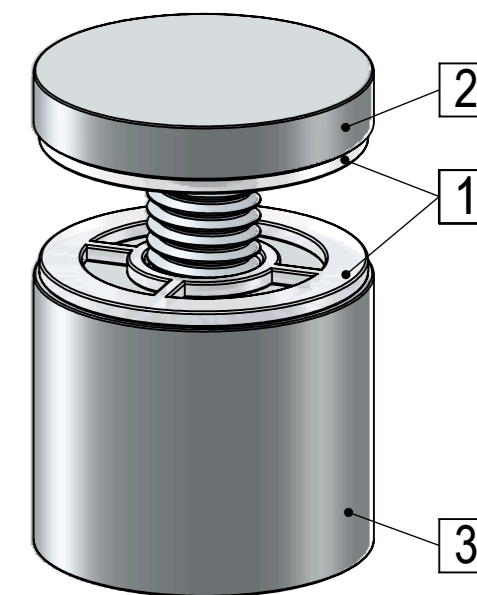

ITEM NO.	PART NUMBER	DESCRIPTION	QTY.
1	FAH30_Washer		2
2	HM1127A(FHA30-25)-Reverse_Thread		1
3	FAH30-30_Body-30x25-Reverse_Thread		1

Title : FAH30-30			Scale : 1.5:1		
			Sizes : Letter Landscape	Customer:	
		Material:	Finish	Qty :	Rep :
		N°programme laser	N°prog. Mécanum.	N° Plan : FAH30-30	