

Maximum Thickness
[3/8"]
9mm

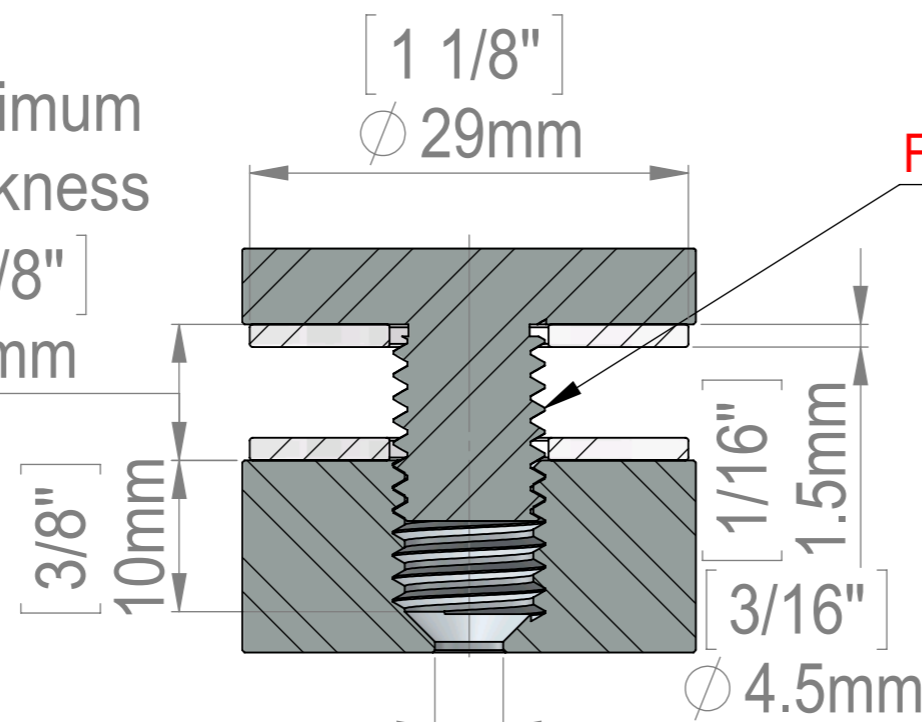

SECTION E-E
SCALE 2 : 1

M10 Thread

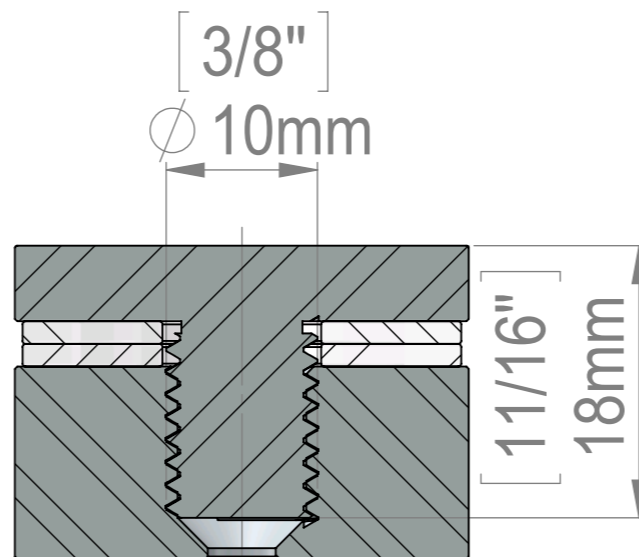
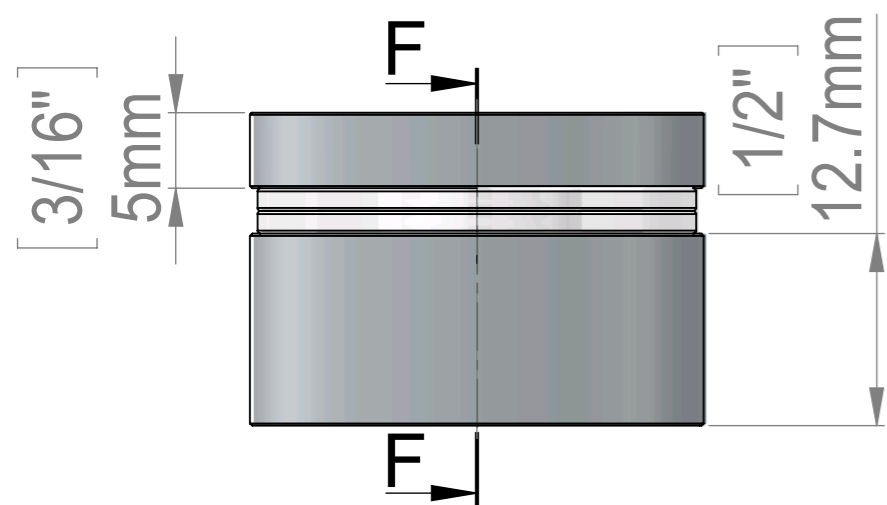

SECTION F-F
SCALE 2 : 1

Attention
Reverse Threaded
For Tamper Proof Purposes

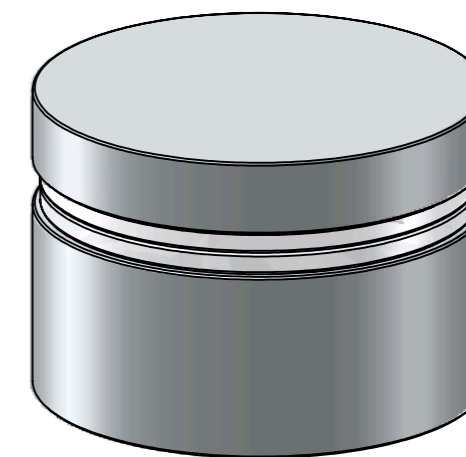
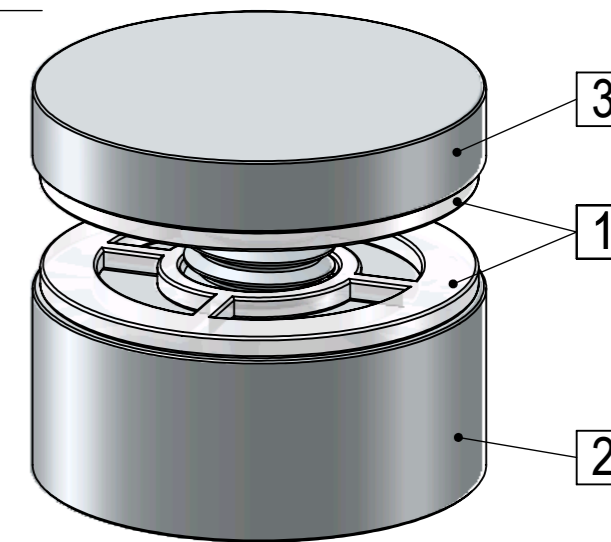

ITEM NO.	PART NUMBER	DESCRIPTION	QTY.
1	FAH30_Washer		2
2	FAH30-12_Body-30x12-Reverse_Thread		1
3	HM1126A(FHA30-12)-Reverse_Thread		1

Title : FAH30-12			Scale : 2:1	Customer:	
			Sizes : Letter Landscape	Qty :	Rep :
Material:		Finish		N° Plan : FAH30-12	
N°programme laser		N°prog. Mécanum.			