

Maximum Thickness  
 $[9/16"]$   
 14mm

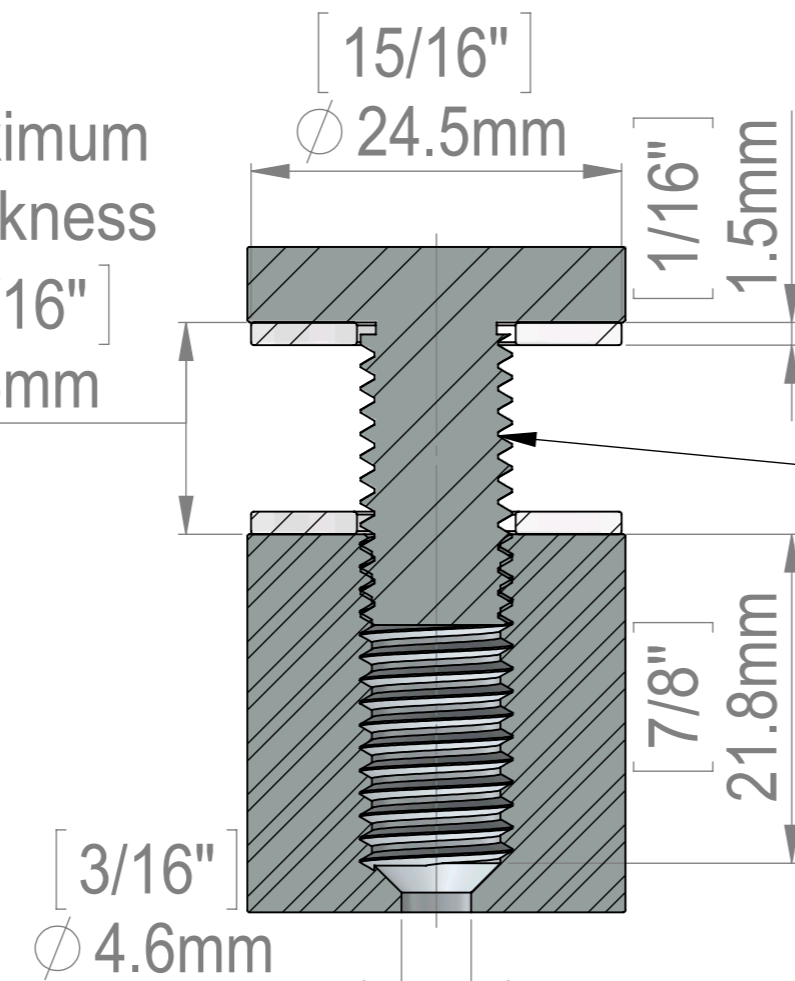

SECTION E-E  
 SCALE 2 : 1  
 M10 Thread

Attention  
 Reverse Threaded  
 For Tamper Proof Purposes

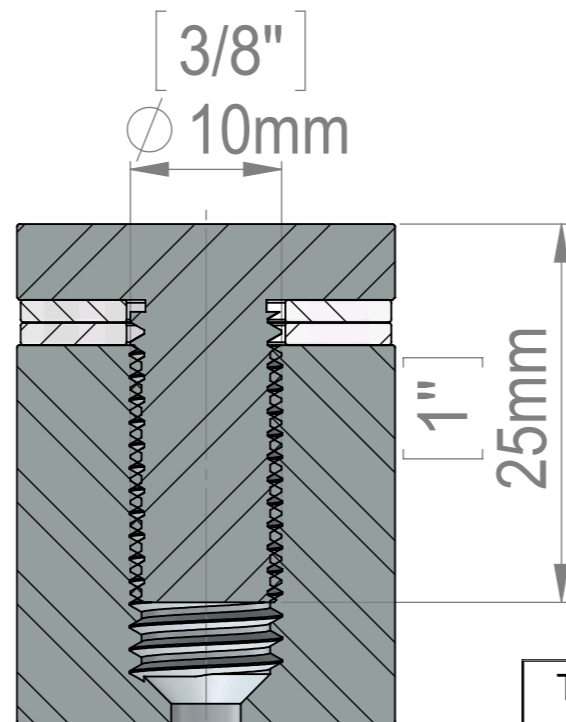
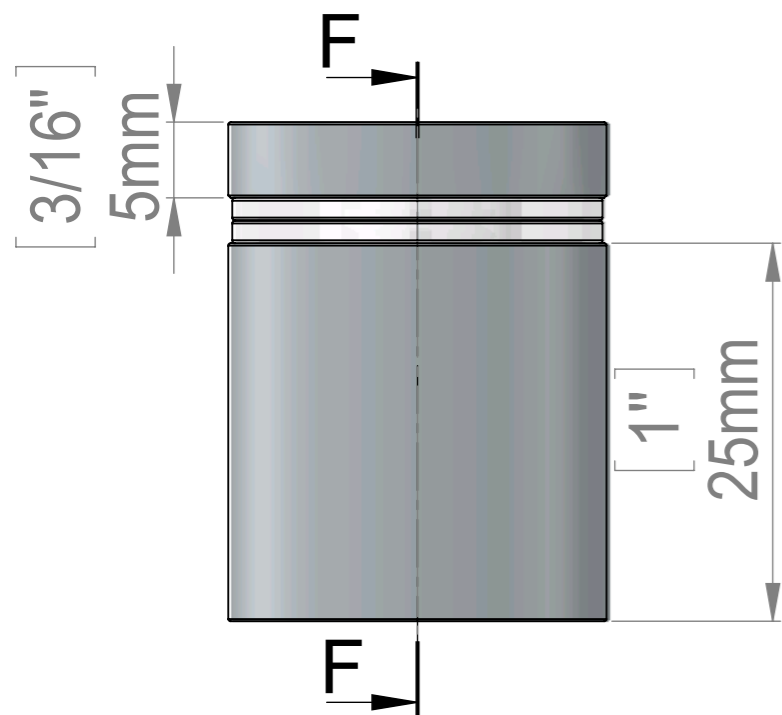
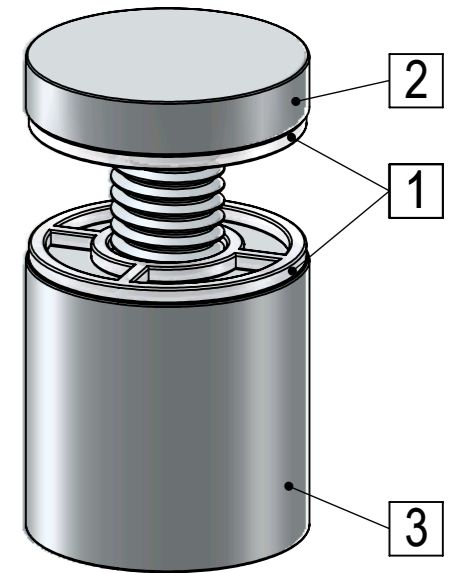

SECTION F-F  
 SCALE 2 : 1



ITEM NO.	PART NUMBER	DESCRIPTION	QTY.
1	FAH25_Washer		2
2	HM1122A(FHA25-25)-Reverse_Thread		1
3	FAH25-30_Body-25x25-Reverse_Thread		1

Title : FAH25-30		Scale : 1.5:1	Customer:	
		Sizes : Letter Landscape	Qty :	Rep :
Material:		Finish		
N°programme laser		N°prog. Mécanum.	N° Plan : FAH25-30	