

Maximum Thickness  
 $\left[ \frac{3}{8}'' \right]$   
 9mm

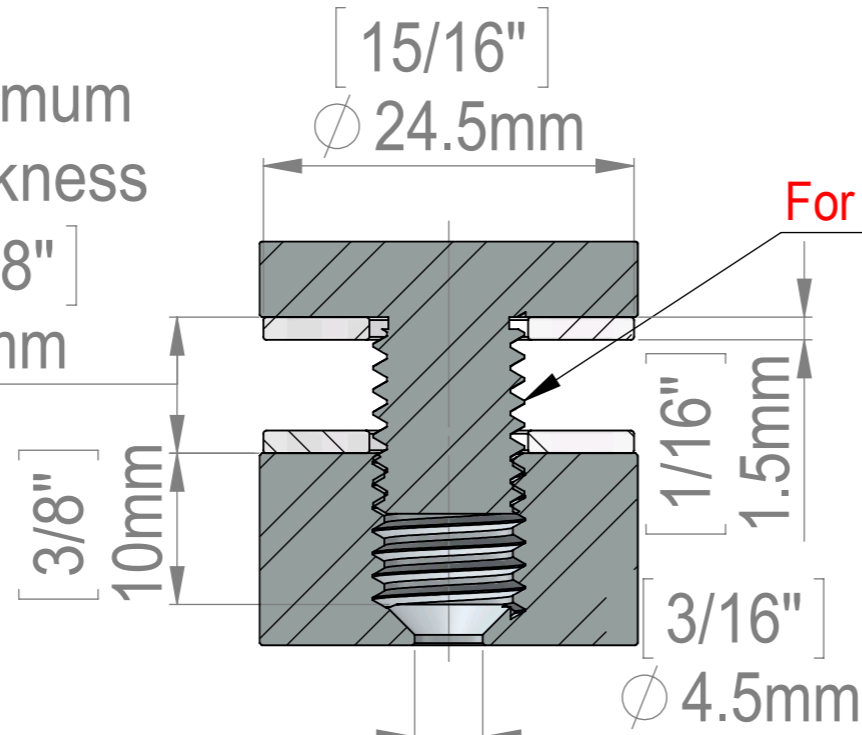

SECTION E-E  
 SCALE 2 : 1

Attention  
 Reverse Threaded  
 For Tamper Proof Purposes

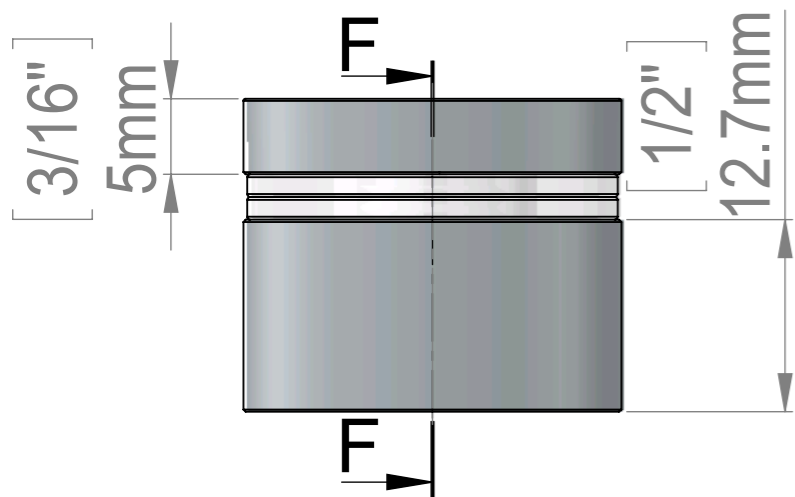
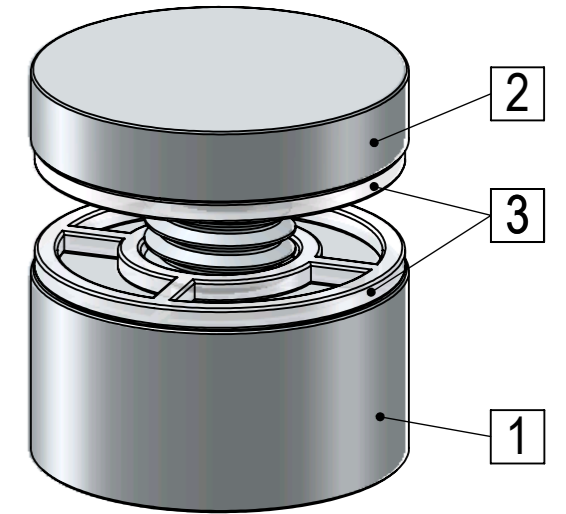

M10 Thread

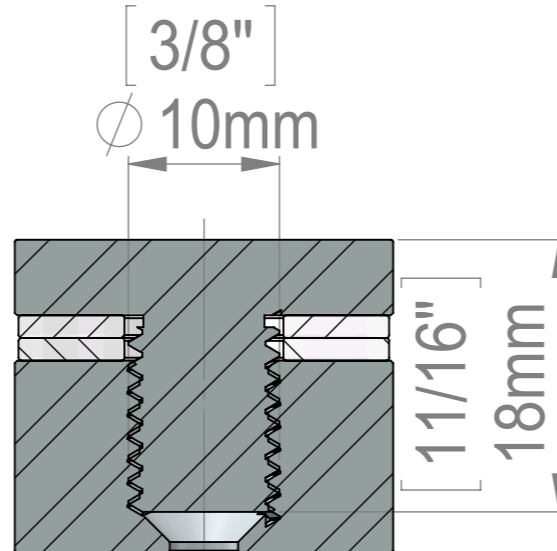

SECTION F-F  
 SCALE 2 : 1

ITEM NO.	PART NUMBER	DESCRIPTION	QTY.
1	FAH25-12_Body-25x12-Reverse_Thread		1
2	HM1121A(FHA25-12)-Reverse_Thread		1
3	FAH25_Washer		2

Title : FAH25-12		Scale : 2:1	Customer:	
		Sizes : Letter Landscape	Qty :	Rep :
Material:		Finish		
N°programme laser		N°prog. Mécanum.	N° Plan : FAH25-12	