

SECTION E-E
SCALE 1.5 : 1

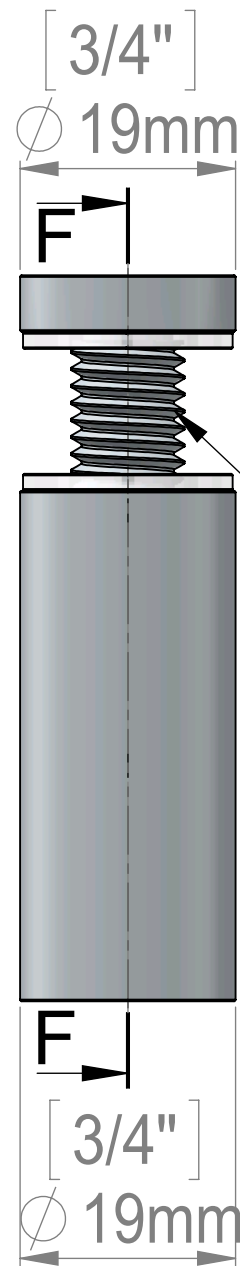

Maximum Thickness
[9/16"]
14mm

Attention
Reverse Threaded
For Tamper Proof Purposes

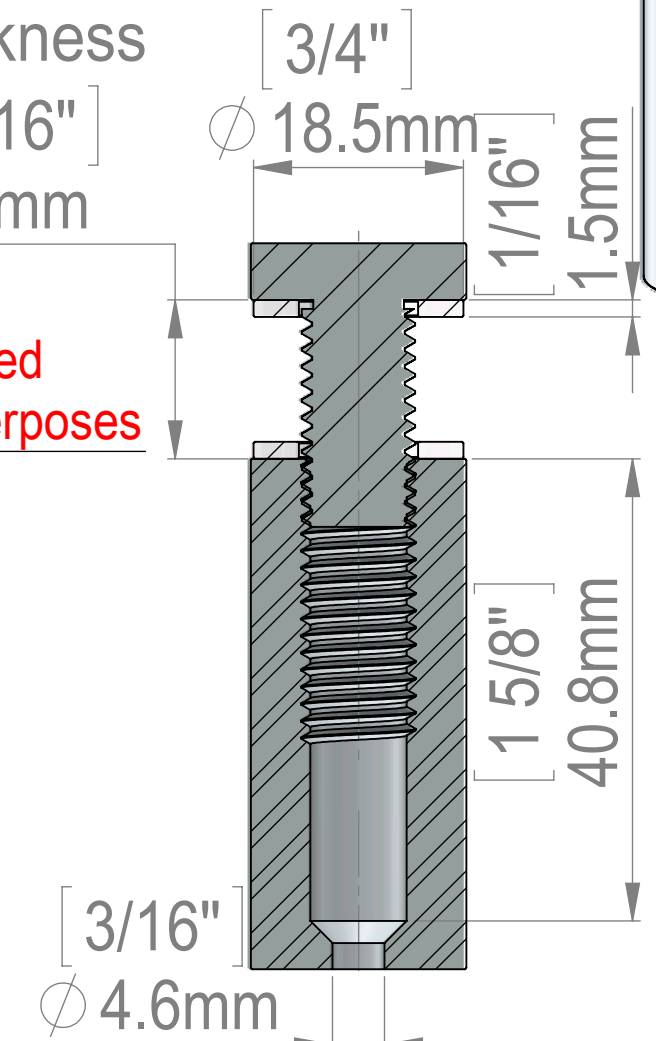

SECTION F-F
SCALE 1.5 : 1

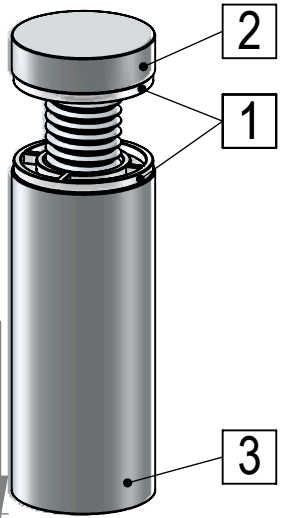

ITEM NO.	PART NUMBER	DESCRIPTION	QTY.
1	FAH19_Washer		2
2	HM1112A(FHA19-25)-Reverse_Thread		1
3	AL19-50_Body-19x45-Reverse_Thread		1

Title : FAH19-50		Scale : 1:1	
		Customer:	
Material:		Finish	
N°programme laser		N°prog. Mécanum.	
		Qty :	Rep :
N° Plan : FAH19-50			