

Maximum  
Thickness  
 $\left[ \frac{9}{16}'' \right]$   
14mm

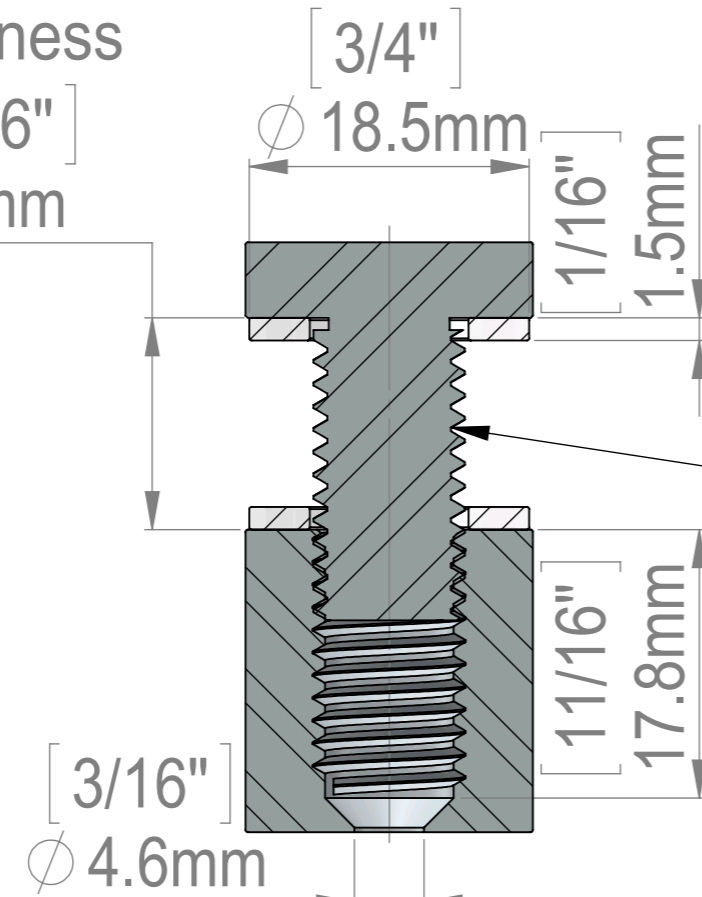

SECTION E-E  
SCALE 2 : 1  
M10 Thread

Attention  
Reverse Threaded  
For Tamper Proof Purposes

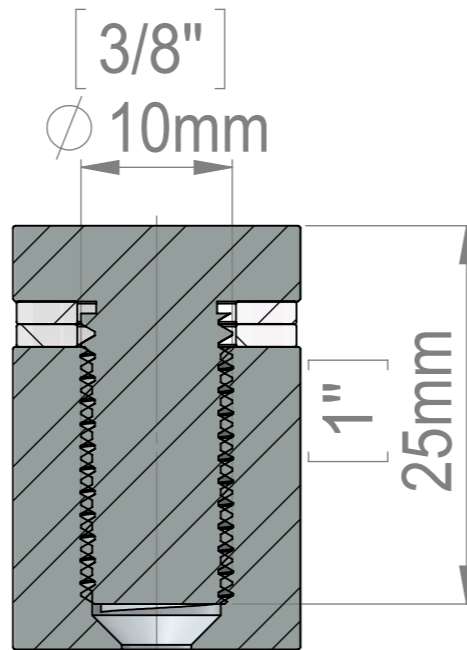
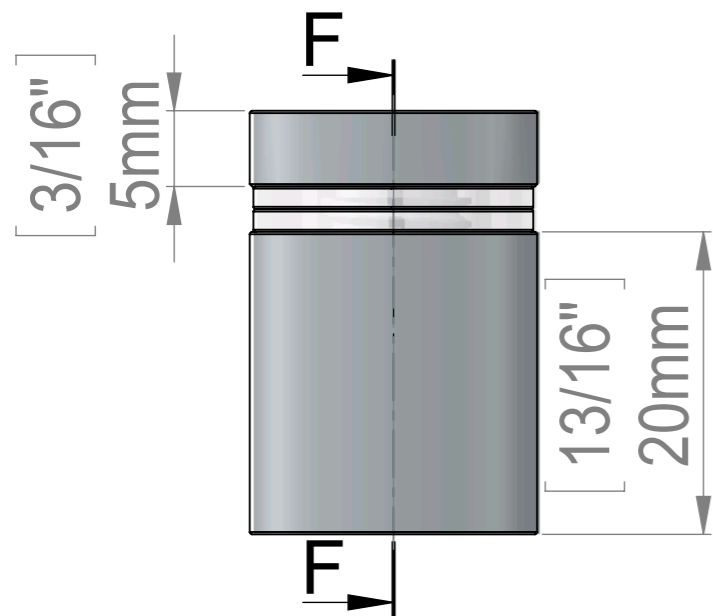
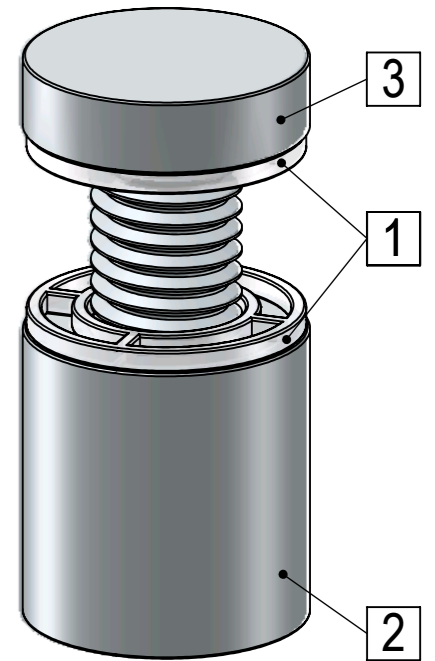

SECTION F-F  
SCALE 2 : 1



ITEM NO.	PART NUMBER	DESCRIPTION	QTY.
1	FAH19_Washer		2
2	FAH19-25_Body-19x20-Reverse_Thread		1
3	HM1112A(FHA19-25)-Reverse_Thread		1

Title : FAH19-25		Scale : 2:1	Customer:	
		Sizes : Letter Landscape	Qty :	Rep :
Material:		Finish		
N°programme laser		N°prog. Mécanum.	N° Plan : FAH19-25	