

SECTION F-F
SCALE 1.5 : 1

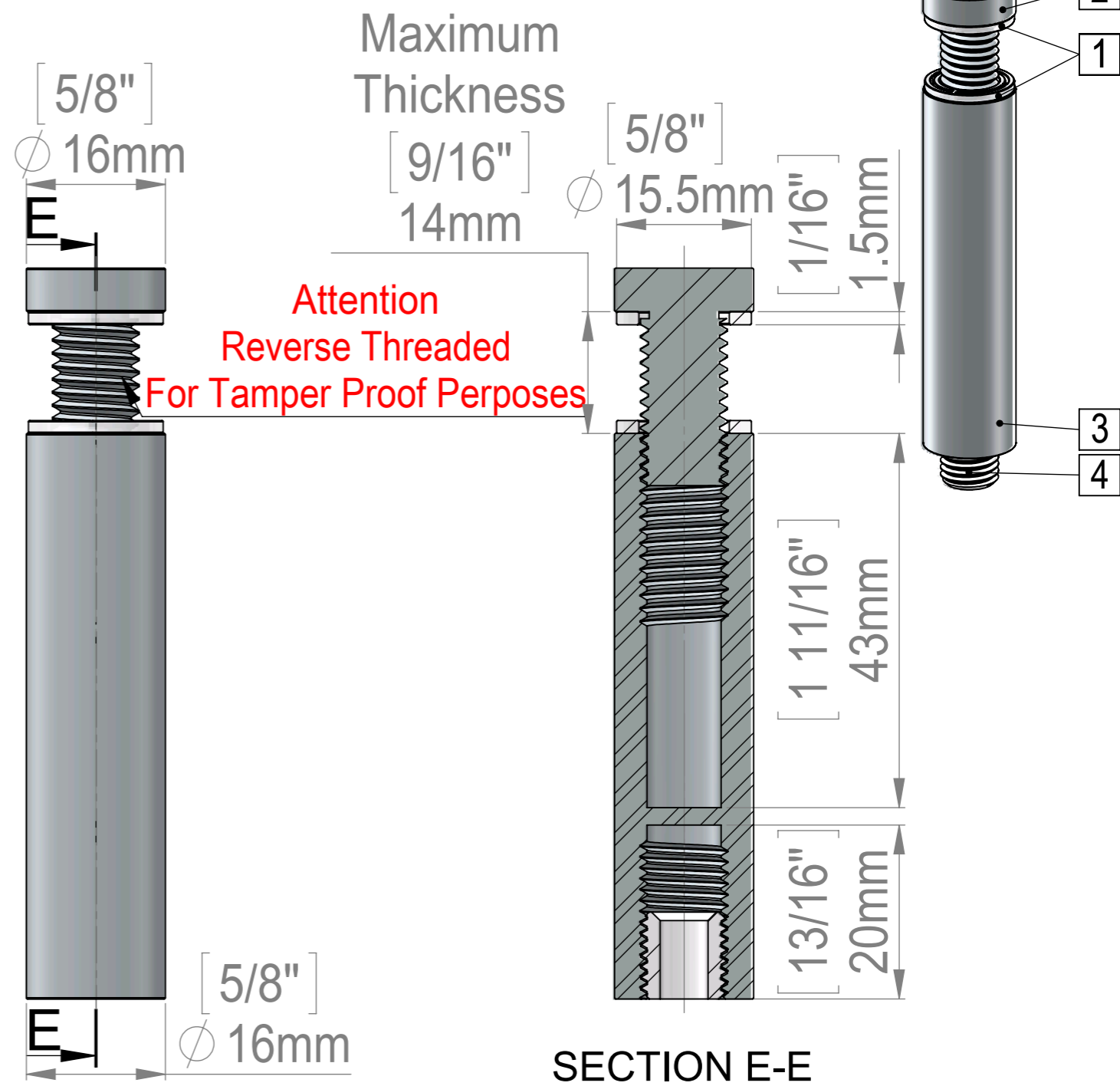

SECTION E-E
SCALE 1.5 : 1

Attention
Reverse Threaded
For Tamper Proof Purposes

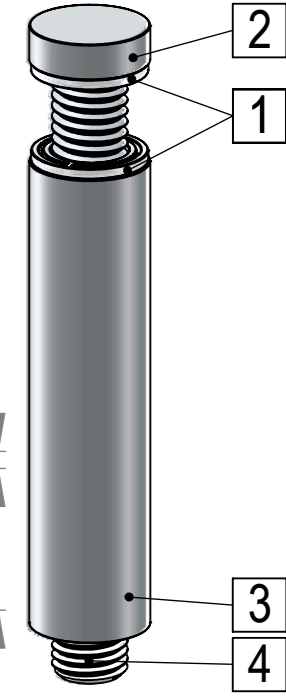

ITEM NO.	PART NUMBER	DESCRIPTION	QTY.
1	FAH16_Washer		2
2	HM1107A(FHA16-25)-Reverse_Thread		1
3	FAH16-70_Body-16x65-Reverse_Thread		1
4	M10x10mm-Screw		1

Title : FAH16-70		Scale : 1:1	Customer:	
		Sizes : Letter Landscape	Qty :	Rep :
Material:		Finish		
N°programme laser		N°prog. Mécanum.	N° Plan : FAH16-70	